

nurus

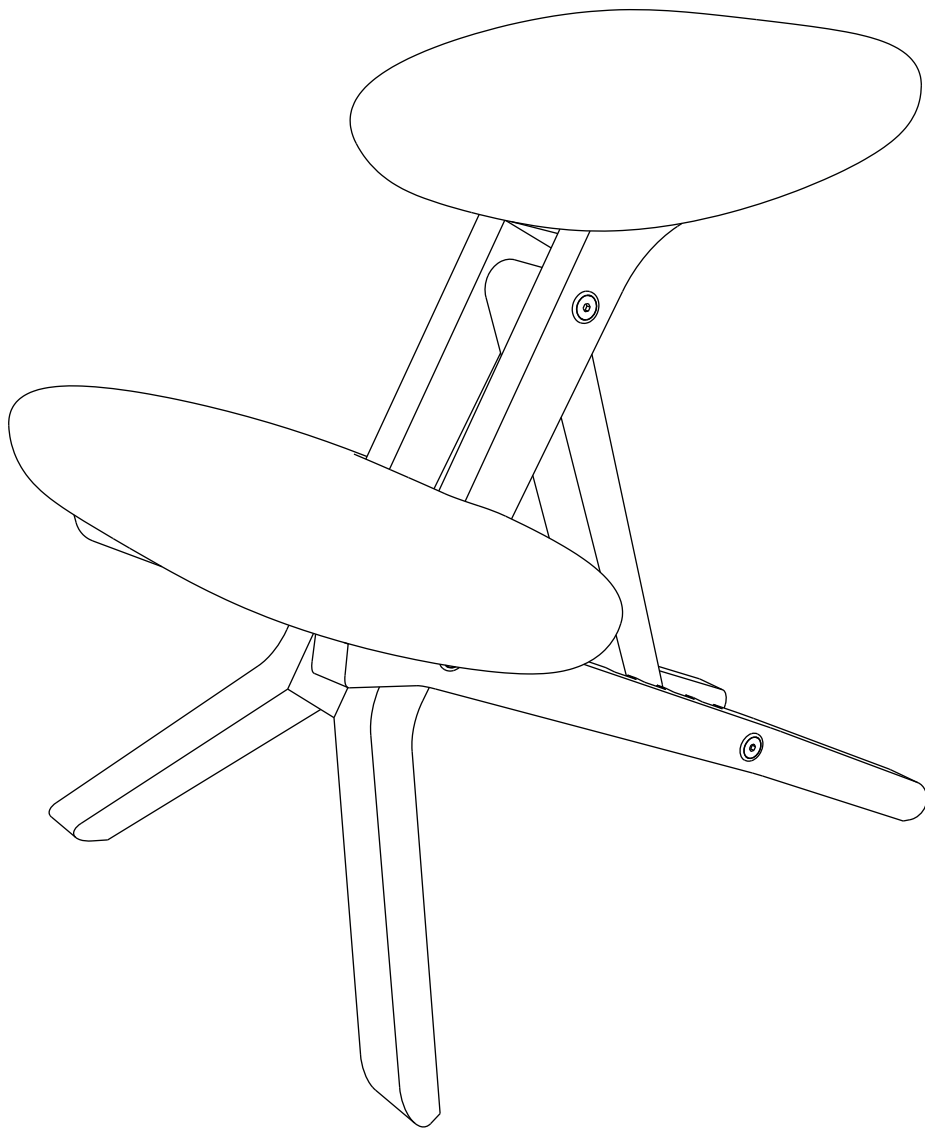

MATILDA

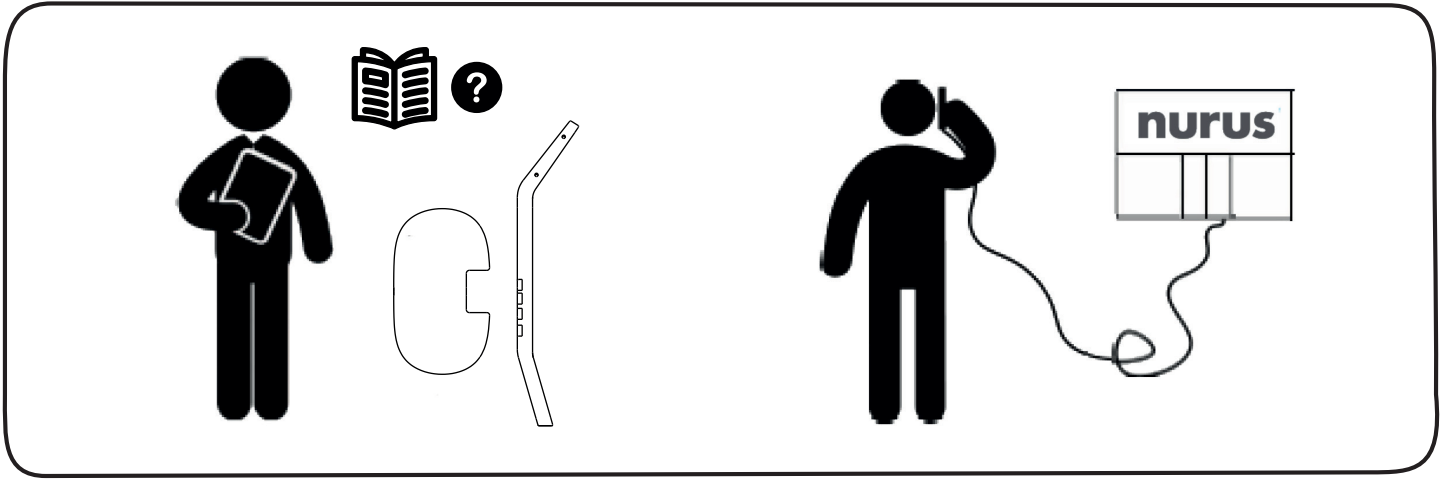
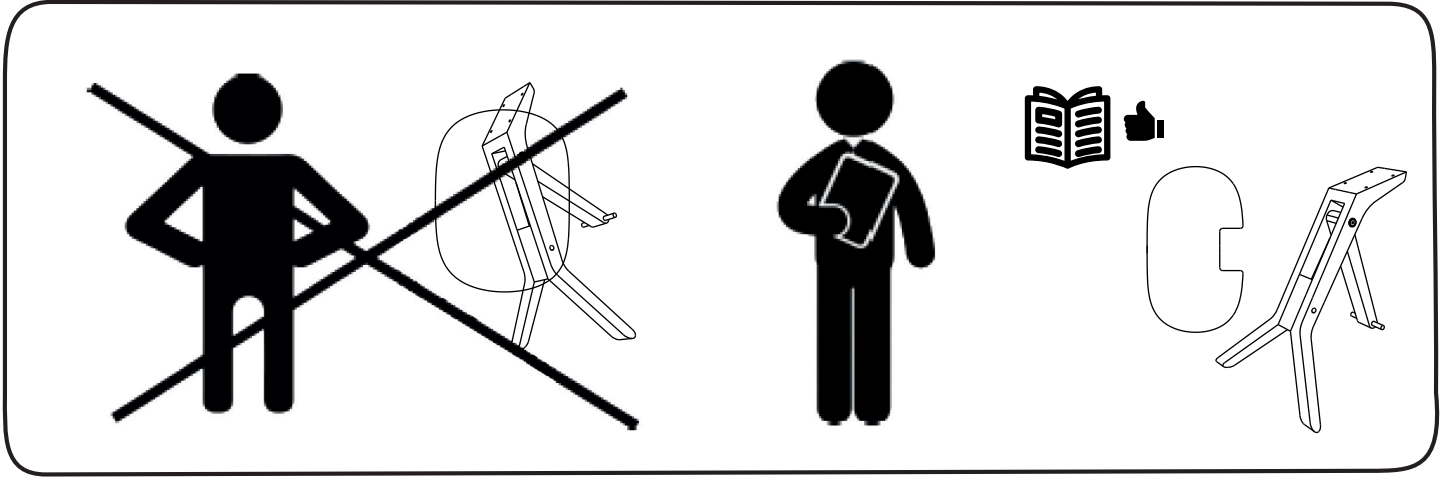

Matilda koltuğun montajı için 1 kişi yeterlidir.



Montaj için montaj kitinde gösterilen malzemeleri kullanınız.



Montaj sırasında yüksek torklu el aletleri kullanmayınız.

Kutu İeriđi

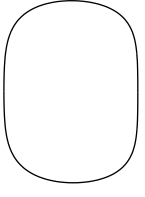

1 X

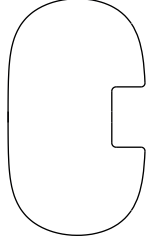

1 X

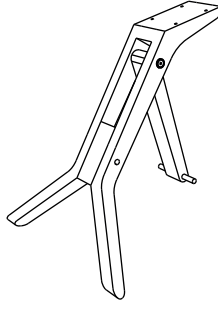

1 X

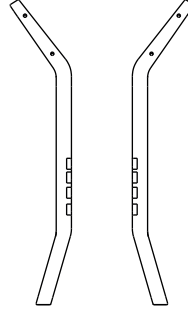

1 X

Montaj Kiti



2 X



2 X



4 X



M6 40 IMBUS



M6 60 IMBUS



M8 40 HB



2 X

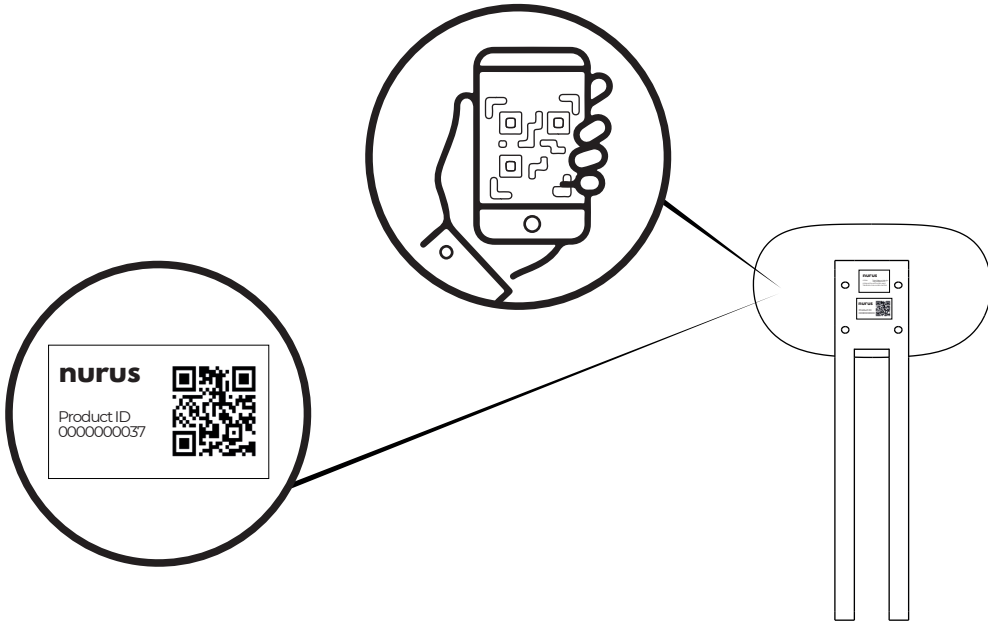

Satış sonrası hizmetlerimizden ve size özel kampanyalarımızdan yararlanabilmek için koltuđunuzun altındaki QR kodu okutarak ürününüzün kaydını yaptırabilirsiniz.

1

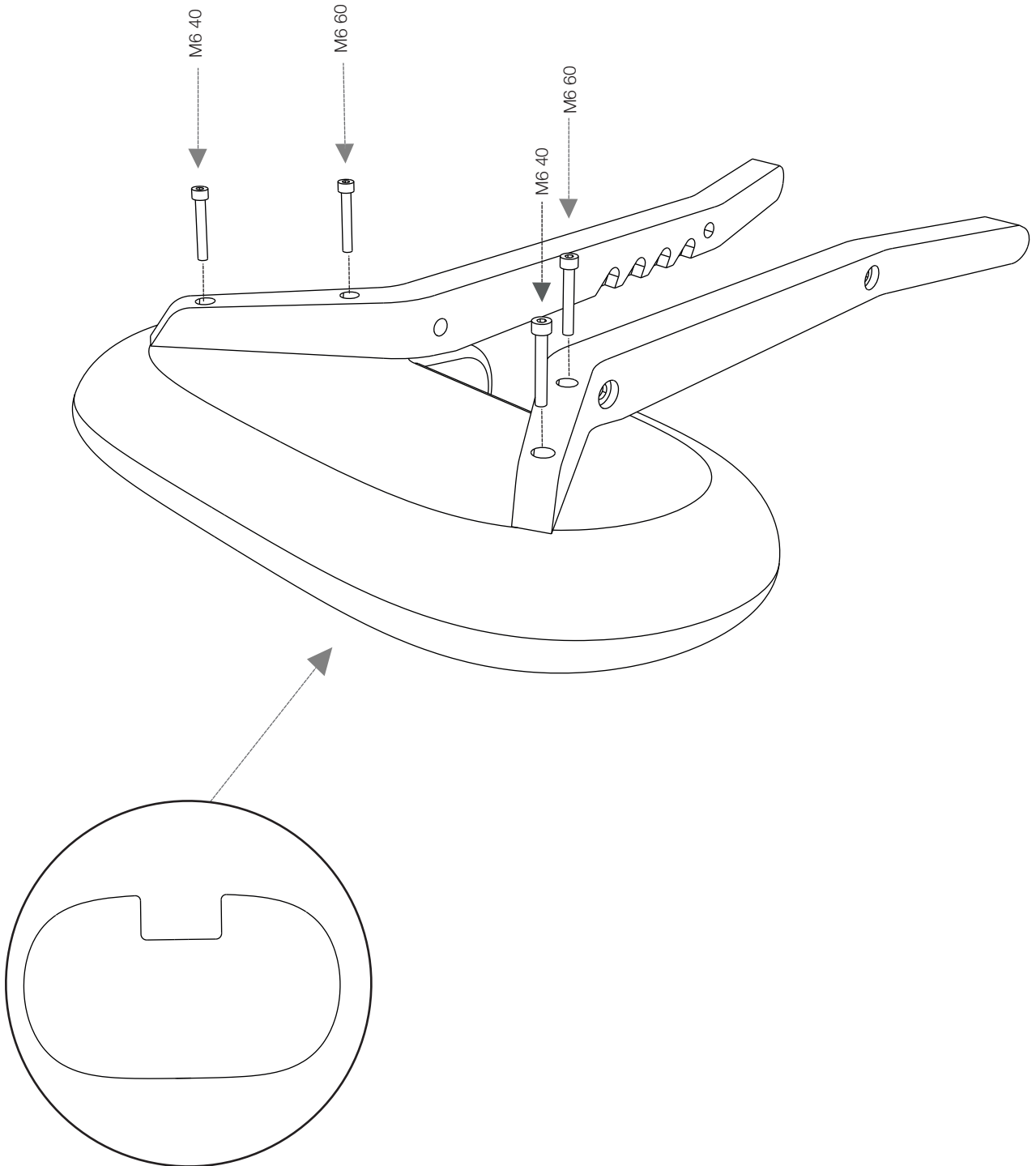

2

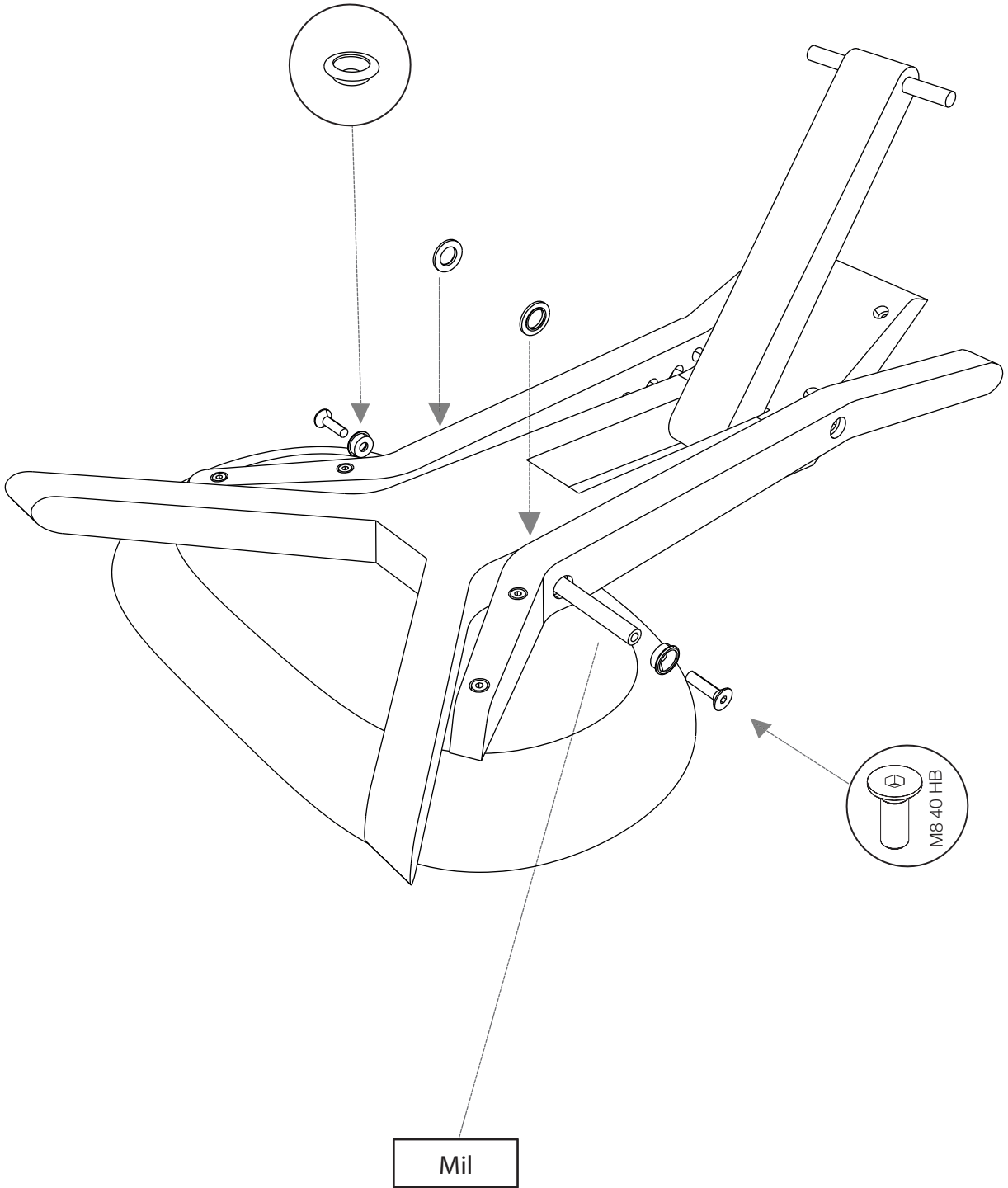

3

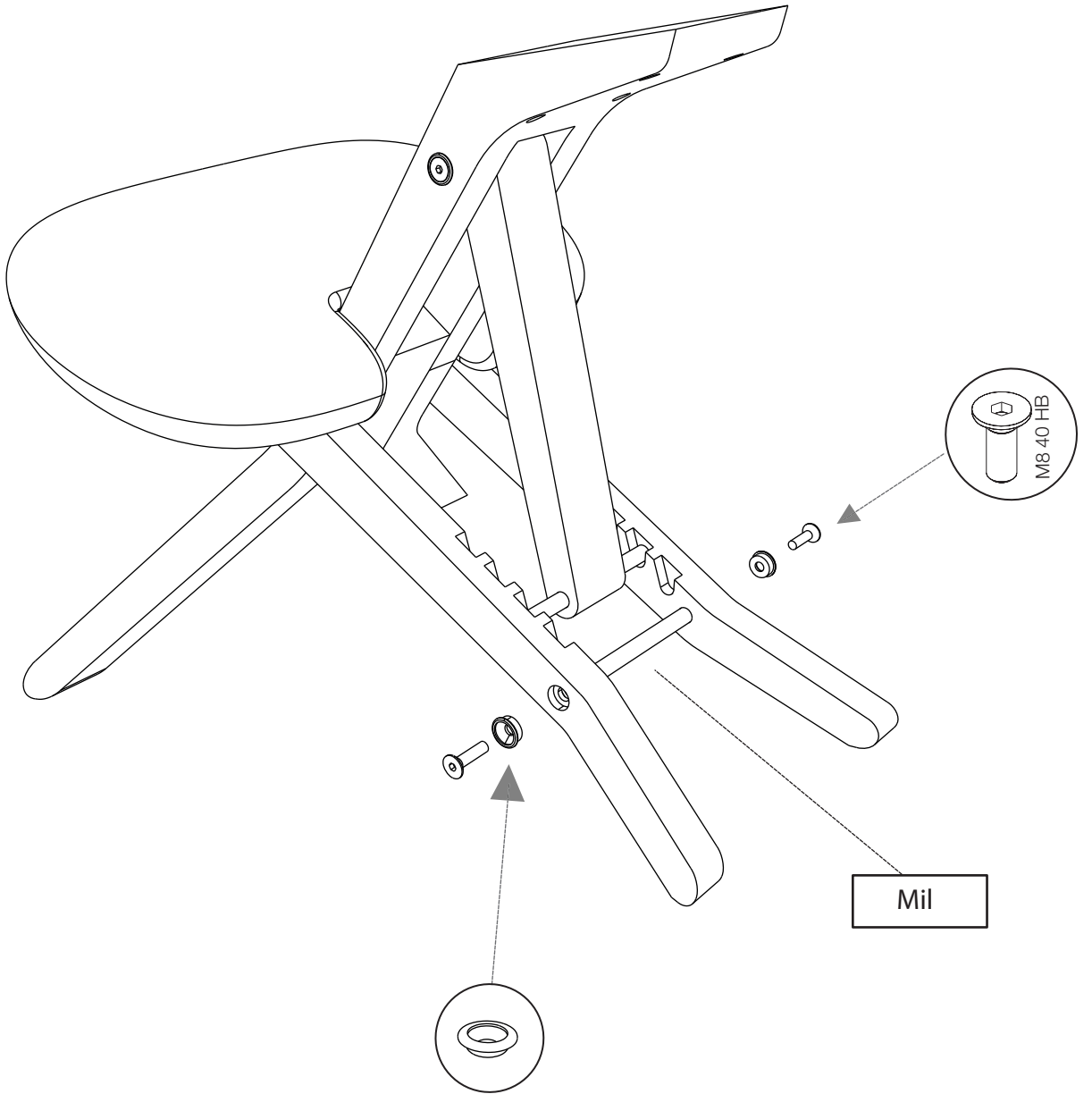

4

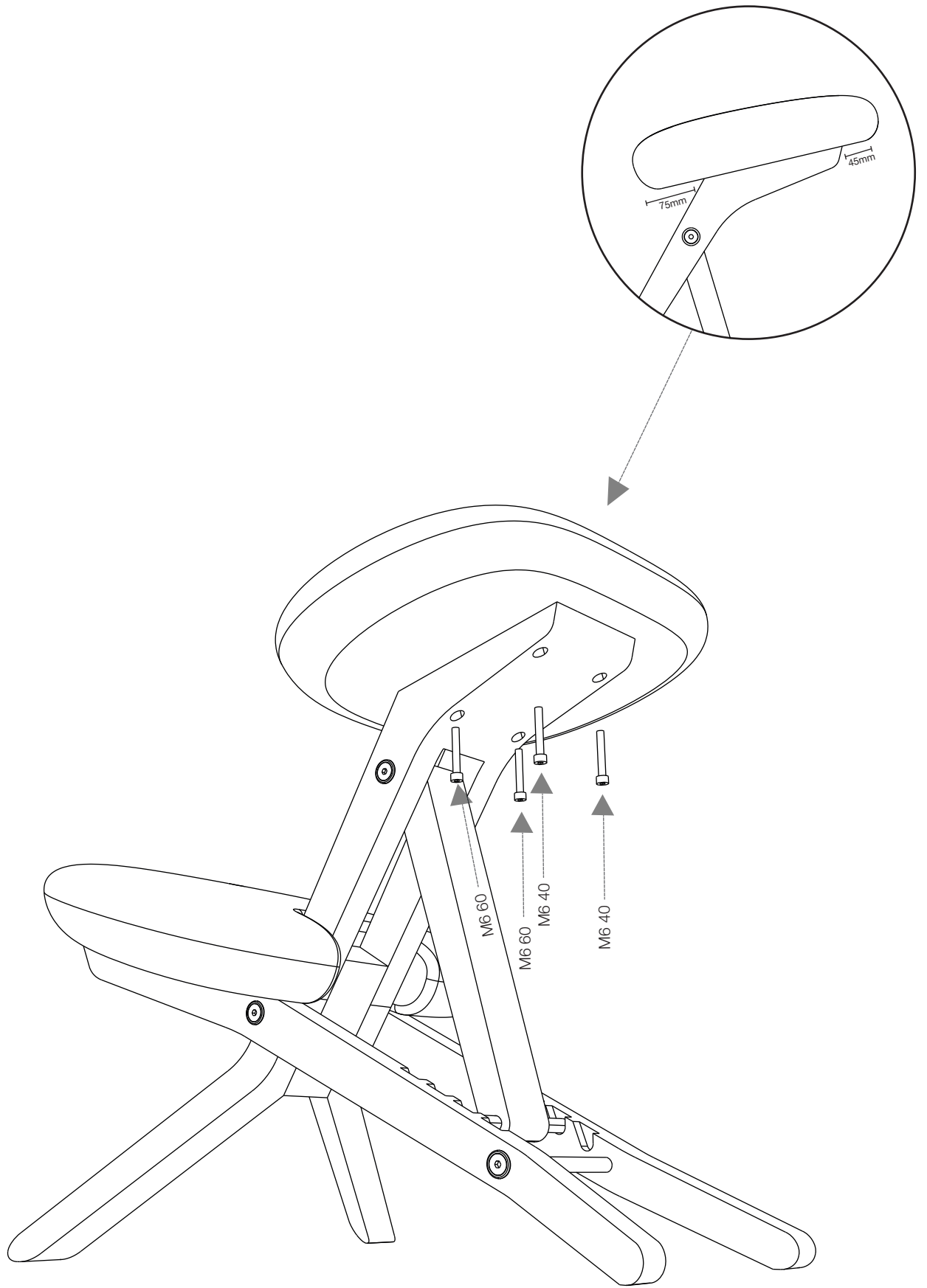



Matilda nasıl kullanılmalıdır?

Diz çökme pozisyonuna geçmeden önce, koltuğa oturarak başlayın, sonrasında dizlerinizi pedlerin üzerine hafifçe yerleştirin.

Bu pozisyonda ağırlığınızın büyük kısmını kalçalarınız taşımalıdır. Alt ped, öne doğru kayıormuş gibi hissetmenizi engellemek için kaval kemiklerinize destek görevi görür.

Tüm çalışma pozisyonlarında olduğu gibi, Matilda'yı kullanırken de gün içinde pozisyonunuzu sık sık değiştirmek önemlidir.

Hatırlatma:

Sizin ve özellikle çocukların kullanımında bir tehlike yaşanmaması adına hatırlatmak isteriz ki; Matilda 45 ile 120 kg arasındaki kullanıcılara uygundur.